

Nur Task (a) und (b) -- bei Fun (c) optional

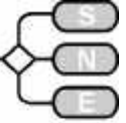

C14 Supply Chain Management Definition

This comparison addresses discrete modelling and simulation. Supply Chain Systems are usually straight forward, but they have different downstream and upstream flows between factories, distributors and wholesalers. While the downstream flow characterises the flow of materials, the upstream flow represents the various orders, which often depend not only on the local material flow downstream, but also on the global status of the system.

The flow of orders may be modelled in many different ways:

- Templates for chain supply
- Message channels for modelling flow of orders
- Timeless orders represented by events directly
- Planning tables control order sequences

This comparison considers a relatively simple Supply Chain, consisting of four factories, of four suppliers, and of a group of wholesalers (fig. 1.)

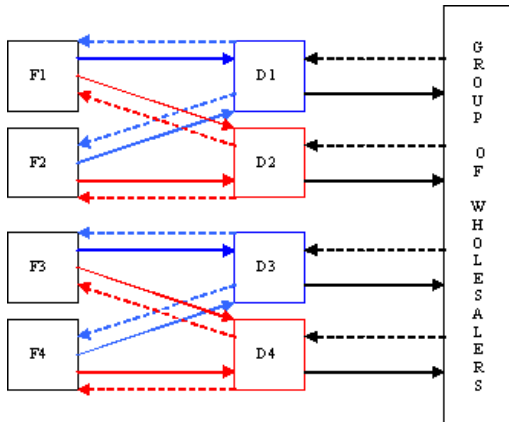

Figure 1: Supply chain with 4 factories, 4 distributors and a group of wholesalers

Factories

The 4 factories F_i are supposed to be supplied with unlimited raw materials. The factories produce 12 different products p_k (uniformly distributed) and supply the distributors. The factories do not produce all types of products; each factory only produces 6 different types of products (table 1). The interarrival time of products is distributed exponentially with parameter 600 seconds (independent of type of product).

The investigations consider a time horizon of 30 days, beginning at 00.00 at the 1st day and ending at 24.00 at the 30th day. The factories produce all the time around the day, starting at the 1st day, 00.00, ending with 30th day, 24.00 (after 720 hours).

F_1	F_2	F_3	F_4
p_1	p_7	p_4	p_{10}
p_2	p_8	p_5	p_{11}
p_3	p_9	p_6	p_{12}
p_4	p_{10}	p_7	p_1
p_5	p_{11}	p_8	p_2
p_6	p_{12}	p_9	p_3

Table 1: Production Plan

Distributors

The 4 Distributors D_i supply a group of wholesalers and order from the factories, following different order strategies. First, the factories produce for 7 days, so that they have a stock of products. Then the distributors start with their orders (i.e. on the 8th day, 00.00, or after 168 hours); at this time all distributors order 10 pieces per product, regardless of the ordering strategy used, to fill their storages.

Further orders are placed once a day, at 00.00. If an order cannot be fulfilled, it is postponed until the next day. An order is only considered fulfilled, if the whole amount of ordered products of one type is available. Furthermore, a supply lead time T_{ji} between distributor and factory (table 2) is must be taken into account.

T_{ij}	F_1	F_2	F_3	F_4
D_1	16	22	20	12
D_2	15	16	13	19
D_3	14	16.5	20	17
D_4	22	13	16.5	18

Table 2: Supply Lead Time in hours

Group of Wholesalers

A group of wholesalers orders stochastically products from the distributors (one product per order):

1. Distributor D_j is stochastically chosen, where $j \in \{1, 2, 3, 4\}$ is uniformly distributed
2. Time in between orders is uniformly distributed over the interval [600,3600] seconds (discrete)
3. Type of product (number k) is uniformly distributed, where $k \in \{1, 2, \dots, 12\}$

The wholesalers start to place their orders to the distributors at the 9th day, 00.00 (after 192 hours).

All orders that cannot be fulfilled are neglected; the wholesalers do not repeat them some time later. But they are regarded at the distributors: the distributor, who could not deliver products of an order, orders these products additionally from the factories at next order time (00.00, next day), regardless which order strategy the distributor uses.

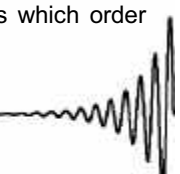

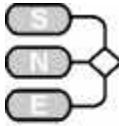

Delivery time from distributor to wholesalers is of no importance, this delivery time does not influence the behaviour of orders.

Products

The products p_k have no specific attributes, as weight or size. They are ordered from factories due to a fixed plan, (table 3, task a and task b) or depending on supply lead time (task c)

Table with 5 columns (D1-D4) and 12 rows (p1-p12) showing factory assignments for products.

Table 3: Fixed order of products by distributors from factories

Each component in the supply chain tries to meet the demand (order) of the downstream component. Also, each supply chain member orders some amount from its upstream supplier.

Model Approach

Give a short explanation of the model approach, especially how the orders and the order strategy are managed or implemented resp. (messages, events ?).

Task a: Simple Order Strategy

Each distributor daily orders a constant amount of 2 pieces per product at the same factory: D1 and D2 order at F1 and F2, D3 and D4 at F3 and F4 (Table 2).

Costs. Transport from factory Fi to Distributor Dj costs 10 € per hour of delivery per order (independent of number of products), the distributor's Dj storage costs are 1 € per product per day (essential is the number of stored products at next order time, where the storage costs are calculated as cost/day times number of stored products, independent from arrival or leaving time of an individual product).

Task a1: Simulate the system once for 30 days and show the stock of distributor D1 over time.

Task a2: Perform 100 simulation runs, calculating maximum, minimum, mean and deviation of

- C = total cost of distributor D1
• N = number of products delivered by distributor D1, and
• R = relative costs of distributor D1, R = C / N

Task b: On Demand Order Strategy

Of certain interest in this model is the influence of different ordering strategies of the distributors.

Instead of ordering a constant number of products (Task a), now the distributor orders as much as needed to meet the demand of the downstream component:

Each distributor accumulates the orders (for each product) of the wholesalers - fulfilled and not - over 24 hours (from 00.00 to 24.00 each day) and orders than this amount from the factories at the next order time (00.00, next day).

Task b1. Simulate the supply chain once for 30 days and show the stock of distributor D1 over time.

Task b2. Perform 100 simulation runs, calculating maximum, minimum, mean and deviation of

- C = total cost of distributor D1
• N = number of products delivered by distributor D1, and
• R = relative costs of distributor D1, R = C / N

Task c: Minimal Supply Time - Strategy

In the previous tasks the distributors place their orders at fixed factories (table 3). Now a distributor Dj tries to order at the factory Fm with the minimal supply lead time Tjm, (Tjm = min (Tji, i=1,...,4).

If the desired amount of products is not available, the factory next in ranking in regard to minimal supply lead time is chosen, and so on. If no factory can deliver, the order is postponed to the next day.

Task c1. Perform 100 simulation runs, calculating maximum, minimum, mean and deviation of

- C = total cost of distributor D1
• N = number of products delivered by distributor D1, and
• R = relative costs of distributor D1, R = C / N

Task c2. Compute a comparative table, showing mean and deviation of C, N and R for all three order strategies.

Shabnam Michèle Tauböck
ARGESIM, c/o TU Vienna
shaby@osiris.tuwien.ac.at

